

Tormek Jig Solutions



Knife Jig
For most knives. Width 45 mm (1¾"). Long knives need to be stiff. Min blade length 60 mm (2¾"). Also for carver's draw knives.



Long Knife Jig
Suitable for long and flexible knives. The 140 mm (5½") width of the jig stabilizes a thin blade. Min blade length 160 mm (6¼").



Scissors Jig
For scissors of all sizes and shears. Also suitable for portable electric hand planer blades.



Axe Jig
For carving and carpenter's axes. Max height of axe 170 mm (6½"). Copes with both straight and curved edges.



Short Tool Jig
For straight shanked carving gouges and V-tools down to 45 mm (1¾") length. Short wood chisels and tools for power carvers. Max tool width 32 mm (1¼").



Gouge Jig
For fingernail shaped turning gouges of any geometry. Plus shaft for turning cutters. Also for bent carving gouges and V-tools. Max tool width 25 mm (1").



Multi Jig
For turning skew chisels, parting and beading tools and roughing gouges. Straight carving gouges up to 50 mm (2") width.



Tool Rest
For turning scrapers, hollowing tools and thin parting tools. Also for cabinet scrapers, screwdrivers and spoke shave blades.



Square Edge Jig
For plane irons and wood chisels. Max tool width 76 mm (3"). Max tool thickness 9 mm (¾"). Safety stops prevent the tool from slipping off the stone.



Planer Blade Attachment
For blades of any length. Blades longer than 270 mm (10½") are relocated in the blade holder. Min width of blade 13 mm (½"). For this jig we recommend the larger T-7 model.



Moulding Knife Attachment
For all makes and shapes of moulding knives with 24, 30 or 38 mm distance between guide hole centres. Max width of blade 100 mm (4"). For this jig we recommend the larger T-7 model.

TORMEK® T-3

Water Cooled Sharpening System

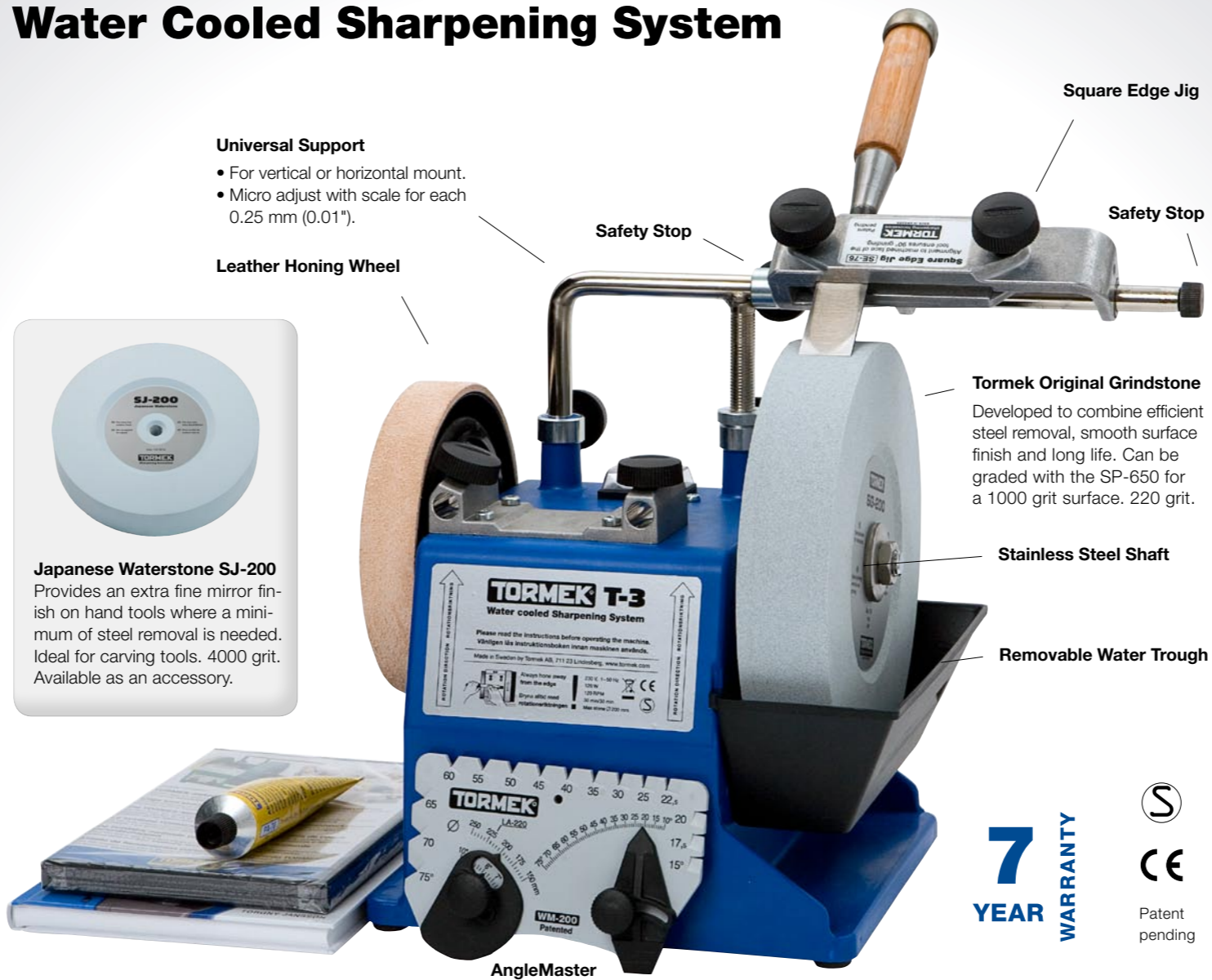

Universal Support

- For vertical or horizontal mount.
- Micro adjust with scale for each 0.25 mm (0.01").

Leather Honing Wheel



Japanese Waterstone SJ-200
Provides an extra fine mirror finish on hand tools where a minimum of steel removal is needed. Ideal for carving tools. 4000 grit. Available as an accessory.

Square Edge Jig

Safety Stop

Tormek Original Grindstone

Developed to combine efficient steel removal, smooth surface finish and long life. Can be graded with the SP-650 for a 1000 grit surface. 220 grit.

Stainless Steel Shaft

Removable Water Trough

AngleMaster

7 YEAR WARRANTY

CE Patent pending

The Ultimate Solution for Square Edges

The Tormek Square Edge Jig SE-76 automatically aligns the tool using its upper and flat side, which ensures a 90° edge. This jig comes with the machine. The jig is used for shaping and sharpening. Honing on the Leather Honing Wheel is carried out using the Universal Support as tool rest.

- Unlike conventional jigs, the upper and flat side of the tool is always parallel to the Universal Support.
- Special designed mounting clamp ensures firm mounting even of tapered chisels.
- Safety stops prevent the tool from slipping off the stone.

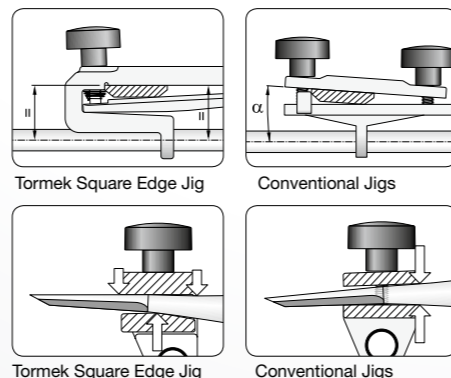

Unique New Truing Tool available

A grinding stone should run true and have a flat surface to give a good result. You can complete your machine with the patented Truing Tool TT-50, so you can keep your grindstone exactly round and flat. Delivered as optional extra.

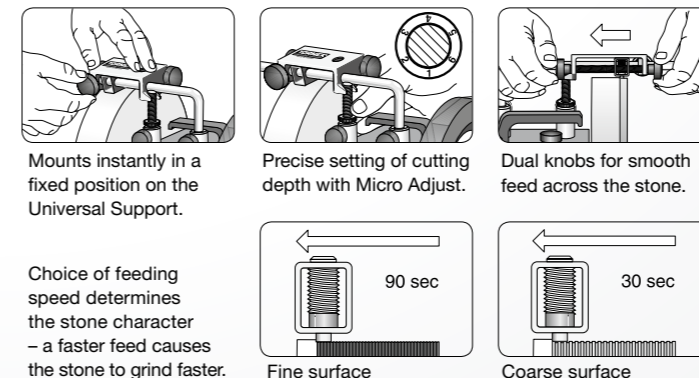

Included with the Tormek T-3



Square Edge Jig
For plane irons and wood chisels. Max tool width 76 mm (3"), max tool thickness 9 mm (¾"). Safety stops prevent the tool from slipping off the stone.



AngleMaster
Sets and measures the edge angle. Adjustable to any stone diameter from Ø 250 mm (10") down to Ø 150 mm (6"). Measures from 10° to 75°.



Honing Compound
For application on the leather honing wheels. Grain size 3 micron (average). Removes the burr and polishes the edge to a mirror finish.



Handbook
Explains the basics in sharpening and how to best work with the Tormek system. Hardcover, with 166 pages and 660 line drawings. By Torgny Jansson.



Tormek DVD
Brings the Handbook instructions to life. 24 minute including a 4 minute introduction to the Tormek way of sharpening.

Additional Accessories



Truing Tool
Trues the grindstone exactly round and flat. Guided by the Universal Support, which also guides the jigs. Dual knobs for smooth feed across the stone.



Stone Grader
The fine side grades the stone for a 1000 grit finish. The coarse side of the grader reverses the stone to normal fast grinding. Activates a glazed stone.



Turning Tool Setter
Replicates the geometry on turning gouges and skews when using the SVD-185 and SVS-50 jigs. With built in edge geometries.

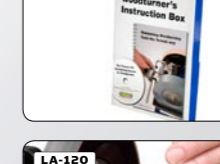

Woodturner's Instruction Box
Contains TNT DVD film and detailed Handbook. Shows how to shape, sharpen and hone all your turning tools.



Profiled Honing Wheels
For the inside honing and polishing of turning/carving gouges and V-tools. Set of two discs, one with a 3 mm (¼") radius and one with a 60° tip.

For narrow tools complement with LA-124 with 2 mm (¾") radius and a 45° tip.

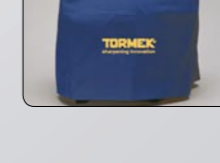

Machine Cover
For protecting the machine from shavings and wood dust.

Note: All jig solutions and accessory images are shown on the T-7 model.

Go vertical for the best results. Price often indicates quality, and we certainly found that to be true in wet sharpeners. Tormek's heavy-duty T-7 proved impossible to stall, no matter how hard we pressed on the tool during sharpening; none of the lower-priced units even came close. Its tool-holding system (tool rest and holders) fit together like hand in glove and gave us dead-on bevels and square ends with little fuss. And the stone wore much slower than less-expensive models we tried. If you sharpen hand tools or knives at least once a week, the versatile T-7 is the sharpener for your shop.

Dave Campbell with John Olson
WOOD Magazine, USA

BEST BUY

As a woodworker and woodcarver for 20 years, I've been plagued by multiple bevels on my tools, cutting angles that were too short or too long. Recently, however, I discovered Tormek and it's a dream come true – a machine that sharpens and hones with the precision of a surgical team.

Roger Schroeder
Wood Carving Illustrated, USA

I have yet to find anything that cannot be sharpened on the Tormek. The honed edge is incredibly fine, and coupled to this dramatic improvement in edge quality is the not insignificant fact that the tools will last far longer, as the sharpening process is so much less aggressive. I am now a total convert to the wet grinding system. It really is Touch and Turn, but you touch far less often and turn far more!

Alan Holtham
The Woodworker, UK

The Tormek TNT-708 Woodturner's Kit is a superbly made, comprehensive kit and does speed up the sharpening process. It is, along with the rest of the Tormek product range, incredibly well made. I have got the process for sharpening a fingernail profile gouge down to under a minute so one can no longer say it is a slow process.

Look at the TTS-100 gouge again (or your own) and compare the cutting edge to that of a dry bench-ground one. It will produce a better finish off the tool and I do think the edge lasts longer as a result. It is well worth the money and as most of us work in other wood disciplines other than turning, the Tormek system becomes more and more attractive!

Mark Baker
Woodturning Magazine, UK

Tormek T-3 Sharpening System

TORMEK T-3, SE-76, WM-200, PA-70, HB-10, DVD-1

TNT-708 Woodturner's Kit

SVD-185, SVS-50, SVD-110, LA-120, MH-380, TTS-100, TNT-300

HTK-705 Hand Tool Kit

SVM-45, SVM-140, SVX-150, SVA-170, SVS-32

Grinding Jigs

SVM-45	Knife Jig		×
SVM-140	Long Knife Jig		×
SVX-150	Scissors Jig		×
SVA-170	Axe Jig		×
SVS-32	Short Tool Jig		×
SVD-185	Gouge Jig		×
SVS-50	Multi Jig		×
SVD-110	Tool Rest		×
SE-76	Square Edge Jig		×
SVH-320	Planer Blade Attachment		
SVP-80	Moulding Knife Attachment		

Accessories

TT-50	Truing Tool		
WM-200	AngleMaster		×
SP-650	Stone Grader		
LA-120	Profiled Honing Wheel		×
LA-124	Narrow discs for LA-120		
PA-70	Honing Compound		×
TTS-100	Turning Tool Setter		×
MH-380	Machine Cover		×
HB-10	Handbook		×
DVD-1	Tormek DVD		×
TNT-300	Woodturner's Instruction Box		×

Dimensions

Width 230 mm (9¹/₁₆"")
Depth 200 mm (7⁷/₁₆"")
Height 260 mm (10¹/₄"")

Grindstone

Aluminium oxide
Ø 200 x 40 mm (8" x 1⁵/₁₆"")
120 rpm, torque 8.4 Nm

Leather Honing Wheel

Ø 145 x 26 mm (5³/₄" x 1")

Main Shaft and stone hardware in stainless steel.

Motor

Industrial single phase
120 W (input)
230V, 50 Hz or 115V, 60 Hz
Duty 30 min/hour
Maintenance free
Silent running, 52 dB
25,000 hour life

Housing

ABS plastic

Weight

Shipping weight 9.0 kg (20.0 lbs)
Machine only 7.4 kg (16.4 lbs)



Easy Sharpening With Full Control



The key word when sharpening the Tormek way is *repeatability*. The tools are guided in jigs – you remove only a minute fraction of the steel at each sharpening, which makes it fast. An extra benefit is that your tools last longer.

You can shape the tool exactly to your needs. Even such complicated shapes as fingernail turning gouges, spoon carving gouges and oval skew chisels with a radiused edge are easily sharpened. Once the shape is created, you can resharpen the edge in less than a minute.

The water cooled slow speed grindstone is in harmony with the physical laws governing the steel tool – the edge does not overheat and lose its hardness.

You finish the sharpening process on the leather honing wheel, which lets you polish the edge to a razor sharpness.

No grinding dust is produced to pollute the air. The steel particles are deposited into the water trough.

The Tormek method is safe. At the low speed, you can fully control the sharpening. Since no sparks are produced, there is no risk to your eyes and you can safely use the machine in areas of high fire risk.

Since 1973 Tormek has introduced many new techniques and set the standard in water cooled sharpening. We are dedicated to sharpening and we are continuously working on new developments to satisfy all your sharpening needs.

Buying a Tormek is a safe investment in quality and performance. You are assured that all future developments will fit your machine.

9082-0812

www.tormek.com



TORMEK
Sharpening Innovation